

**Light Tower**
**LIGHT TOWER  
AL5000**

**Specifications**

30 ft (9.1 m) extended height floodlight produces enough light to illuminate 7-1/2 acres.

Self-braking, erecting and extending hand-operated winch with self-lubricating steel cable is mounted inside the cabinet.

Storage racks for light fixtures are also inside cabinet.

Spring-loaded pin automatically locks galvanized 360° rotatable tower in upright position.

Retractable power cord automatically recoils into protective rotatable mast sleeve to prevent damage when raising, lowering and moving tower.

Light fixtures plug into weatherproof receptacle box at top of tower with UL and CSA-approved connectors.

Individual quick-connect plug-in ballasts installed in galvanized steel boxes.

Control panel is inside, away from the elements. Houses main and branch circuit breakers and hourmeter.

Galvanized outriggers with pre-set position stops insure quick and proper spacing for safe operation in heavy winds.

Single point lifting eye and forklift pockets provided for easy loading and unloading.

# Light Tower AL5000

## Specifications - Standard Unit

Lamps	Metal Halide 4 x 1,000 W
Generator	Brushless 60 Hz, 8.0 kW
Engine	Kubota diesel 13.6 hp
Fuel capacity	30 gal (114 L)
Wheel size	15 in (38 cm)
Axle rating	3,500 lbs (1,588 kg)
Tongue weight travel position	220 lbs (100 kg)
Total weight no fuel	2,425 lbs (1,101 kg)

## Specifications - 20 kW Upgrade

Lamps	Metal Halide 4 x 1,000 W
Generator	Brushless 60 Hz, 20 kW
Engine	Isuzu diesel 34.5 hp
Extra Receptacle Package	
3 each – 30 amp	125/250 volt Twistlock
2 each – 20 amp	120/240 volt GFCI
Fuel capacity	30 gal (114 L)
Wheel size	15 in (38 cm)
Axle rating	3,500 lbs (1,588 kg)
Tongue weight travel position	220 lbs (100 kg)
Total weight no fuel	2,735 lbs (1,245 kg)

## Optional Equipment

Block heater	3/8" Highway safety chains with snap hook
Tough coat paint (front of unit and trailer)	Spare tire and wheel
Plastic fenders	Rubber door hold-down latches
Rock shield (under entire unit)	Extra GFI duplex receptacle with breaker
60 gallon dual fuel tank system	Low temperature coolant mixture (-40 deg F)
Combination ring/ball hitch	Battery heater blanket
Tail light package	Auto-start/stop**
1000 CCA battery	Metal halide 6 x 1,000 W or 8 x 1,000 W lamps
Fuel line heater	
Roda Deaco electronic air shutdown system*	

## Dimensions

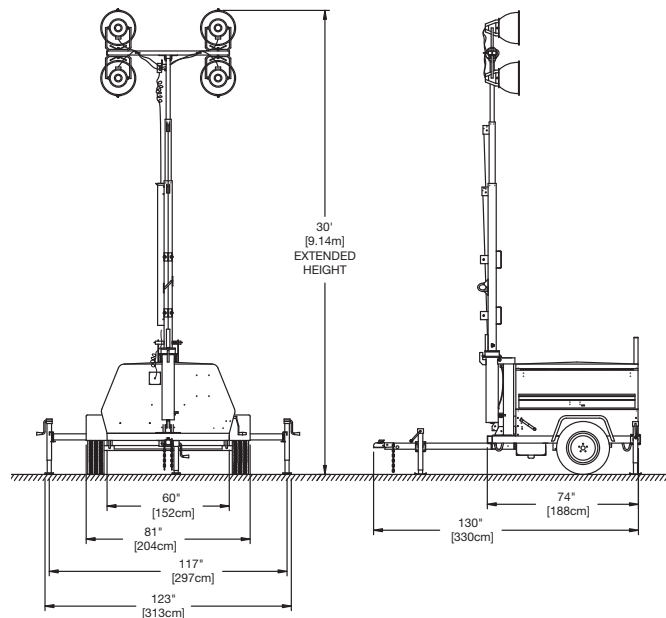
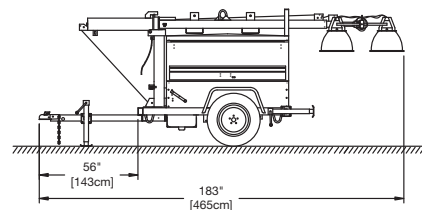
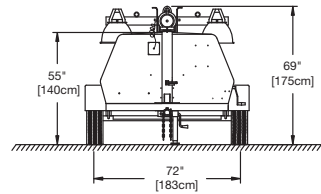

\*Extra GFI and auto-start/stop not available with this system.

\*\*Not available with 8 light configuration.



## Genie Industries, Inc.

A Terex Company

18340 NE 76th Street  
PO Box 97030  
Redmond, WA 98073-9730

TEL +1 (425) 881-1800  
TOLL FREE +1 (800) 536-1800  
PARTS & TECH SUPPORT +1 (800) 228-6444  
FAX +1 (425) 883-3475  
WEB [www.genieindustries.com](http://www.genieindustries.com)

For more information, product demonstration, or details on purchase, lease and rental plans, please contact your local Genie distributor.