

PARTS SUPPLEMENT

OVAL LIGHT PARTS

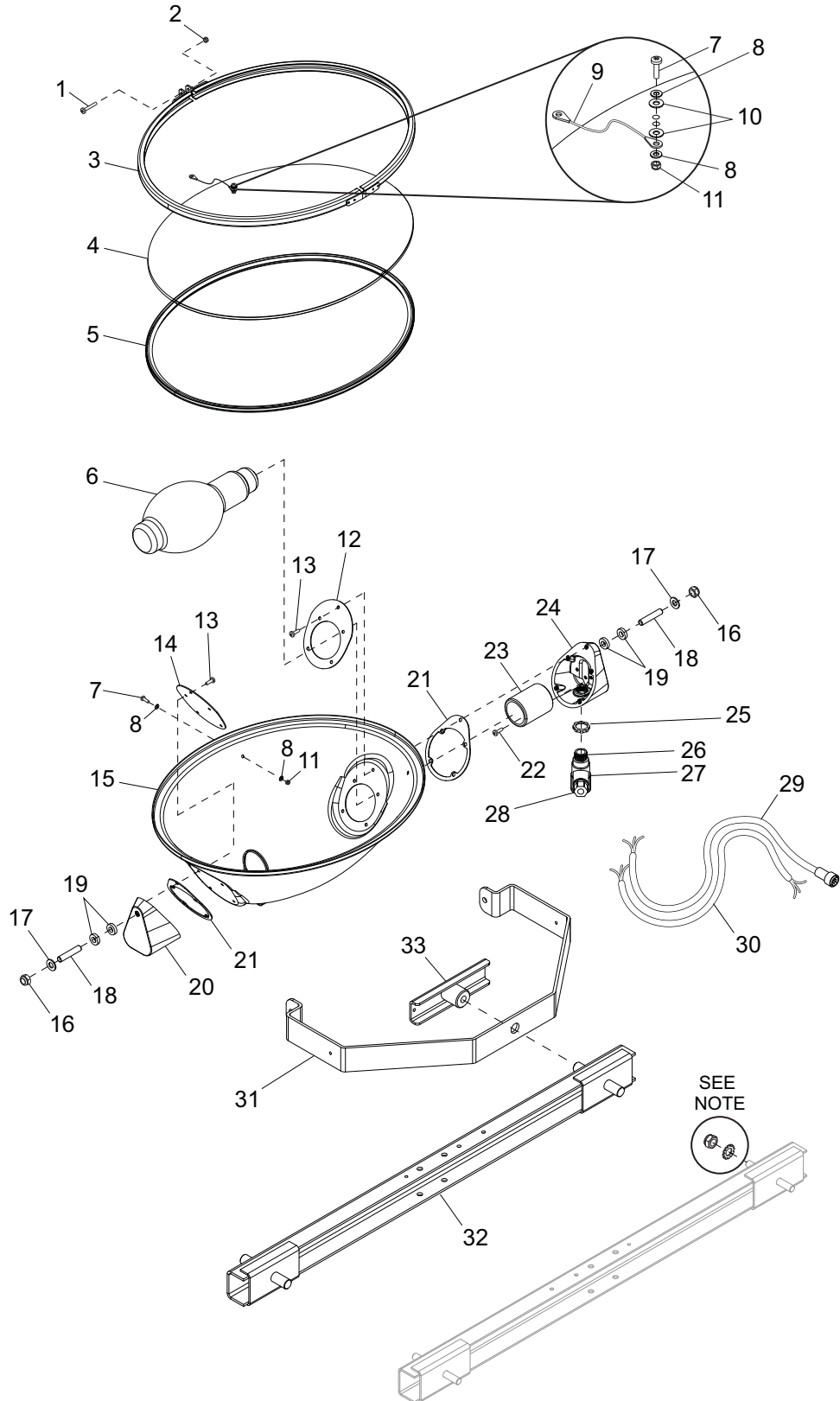

PARTS SUPPLEMENT

ITEM NO.	PART NO.	QTY	DESCRIPTION
1	60304	1	Screw, M5 x 25 pan hd phillips
2	60447	1	Nut, M5 nylock
3	13367	1	Assembly, aluminum ring
4	13369	1	Lens, glass oval
5	13373	1	Gasket, lens oval
6	11391	1	Bulb, 1000W MH short length
7	13399	2	Screw, M4 x 18 pan hd phillips
8	60067	4	Washer, #10 flat .435/.060 SS
9	13370	1	Assembly, tether
10	13372	2	Washer, #4 nylon
11	60051	2	Nut, M4 nylock
12	13376	1	Bracket, socket end plate
13	13388	10	Screw, M5 x 12 slotted hex w/flange
14	13377	1	Bracket, end plate
15	13366	1	Housing
16	60307	2	Nut, 500-13 nylok G5 ZC
17	60309	2	Washer, .500 flat 1.060/.090 ZC SAE
18	13392	2	Stud, trunnion
19	13390	4	Washer, nylon (for part number 13392)
20	13374	1	Support, housing/trunnion
21	13378	2	Gasket, silicone
22	13393	2	Screw, M5 x 12 phillips green
23	13381	1	Socket, bulb
24	13375	1	Support, housing/trunnion
25	15861	1	Nut, special, .500 NPT lock (LN101SC)
26	13386	1	Fitting, nipple
27	13387	1	Connector, weather tight
28	15864	1	Strain relief, .50 NPT watertight .270/.464 ID
29	13383	1	Cord, power quick disconnect
30	13438	1	Cord, power hard wired
31	13368	1	Trunnion, oval light
32	13527B	1	Weldment, mast crossbar (3/4" studs)
33	13403	4	Handle, T - oval light (wing nut)
--	13311	4	Assembly, light fixture - 1000W MH hard wired oval (items 1-28, 30, 31 & 33)
--	13312	1	Assy, light fixture - 1000W MH quick disc.oval (items 1-29, 31 & 33)

NOTE:

Some light towers may require a nut and lock washer to attach the light trunnion to the mast cross bar rather than the T Handle. P/N 60307 Nut, .500-13 nylok and P/N 61107 Washer, external star .500 will be required.